

NEUSPEED®

SHORT-SHIFT KIT

GOLF III, JETTA III 1993-98 2.0L 8V

PART #3-66.10.51

INSTALLATION INSTRUCTIONS

1. Use the illustration as your guide for disassembling and assembling the shift linkage. The shift linkage is located and serviceable from the engine compartment. When disconnecting the plastic rod end from the Selector Shaft, use a screwdriver to unhook the clip **BEFORE** detaching the rod end from the ball pin on the lever.
2. Remove the Selector Shaft and Relay Shaft and replace with the *NEUSPEED* parts. The Selector Shaft has two holes... The top hole is for a 30% reduction and the lower hole is for a 50% reduction. **NOTE:** Align slotted hole of Relay Shaft to seat properly onto threaded rod when tightening nut.
3. Before assembling the shift linkage, lubricate all joints and pivot points with molybdenum grease.
4. After the *NEUSPEED* Short -Shift arms are installed, no further adjustments to the linkage is necessary.
5. Double-check complete installation to be sure nothing interferes with shift linkage, and then check that **ALL** gears engage smoothly and fully **BEFORE STARTING ENGINE OR TEST DRIVING!**
6. **TEST DRIVE CAREFULLY!**

NOTE: If your transmission does not shift smooth, or is hard to get in gear, either an adjustment is required or there are other parts in the shift mechanism that may need to be replaced. See our Catalog for Shift Repair Kits.

*Copyright 1993, *NEUSPEED*®. All rights reserved. Reproduction in whole or in part prohibited.

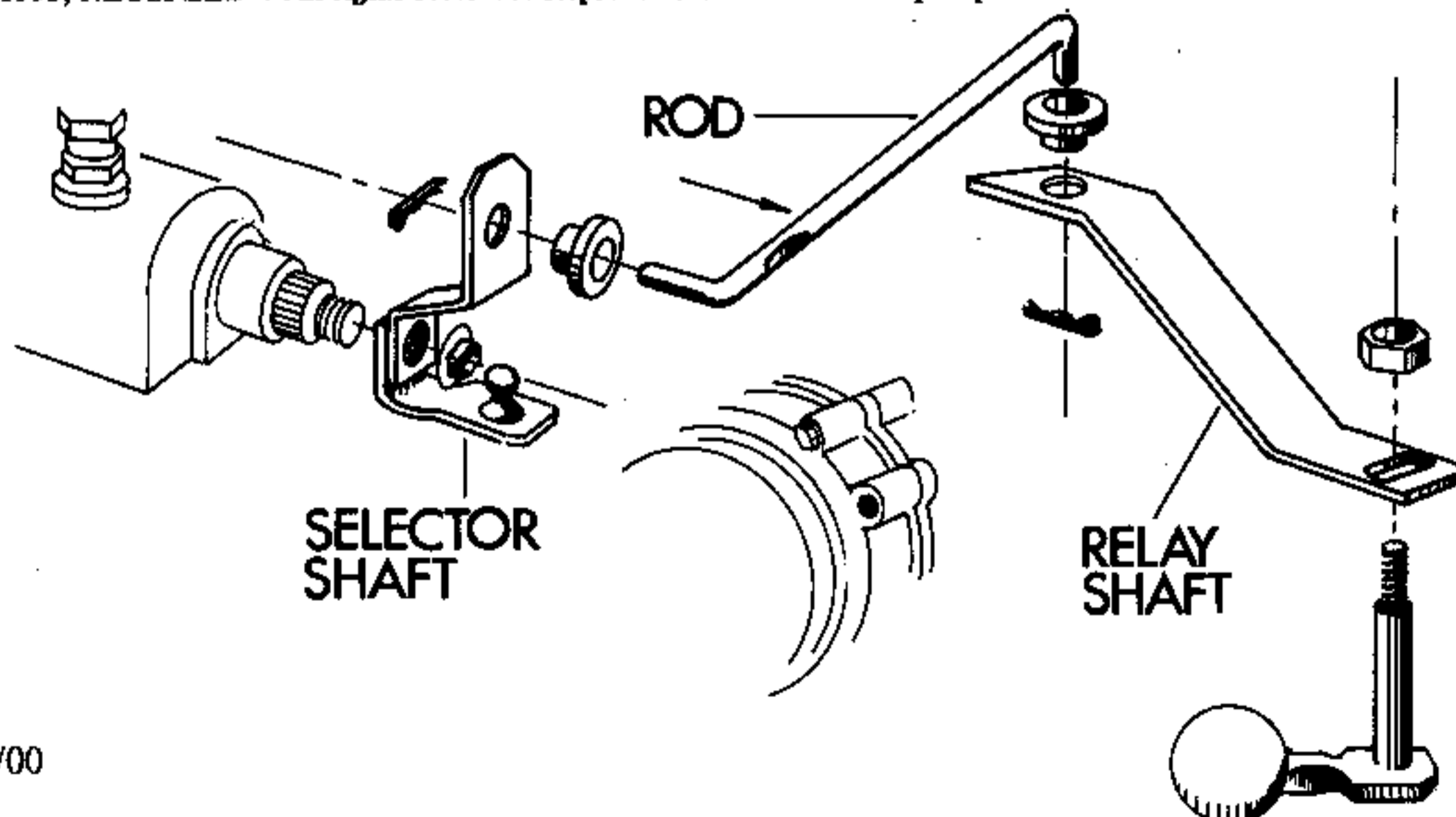

DOC.22.5/00